

MSA 32-160/MSS 32-160 FULLY AUTOMATIC BELLING MACHINE



Applications

- MSA 32-160 automatic in-line machine
- MSS 32-160 automatic off-line machine
- For PVC and PP pipes
- Waste, soil, sewage and pressure pipes
- Electrical conduit pipes
- Double wall and foam core pipes
- Pipe diameters from 32 to 160 mm
- Pipe lengths from 250 to 6000 mm

Optionals

- Conveyor for pipe removal
- Magazine for pipe collection
- Automatic Mecaring seal ring inserting equipment
- Automatic Mecaturn pipe packaging equipment
- Automatic pipe feeding magazine for off-line bellling

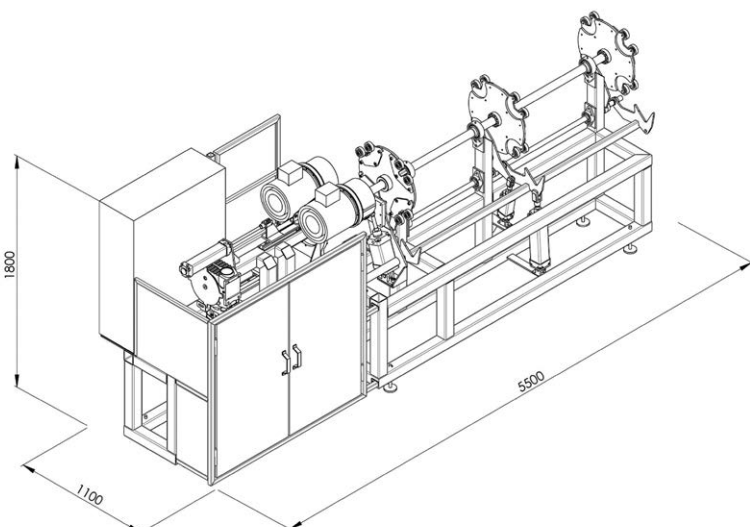

MECANOR

OY MECANOR-ENGINEERING AB

Heinolan Vanhatie 25

FI-15170 Lahti

Finland

TEL +358 40 195 6300

FAX +358 3 781 1082

E-MAIL mecanor@mecanor.com

WWW www.mecanor.com