

MSA 110-400/2 AUTOMATIC IN-LINE PIPE BELLING MACHINE



Applications

- PVC and PP pipes
- Sewage and pressure pipes
- Duct pipes
- Corrugated pipes
- Foam core pipes
- Pipe lengths, nominal 2 to 6 m
- Pipe diameters 110-400 mm

Optionals

- Automatic pipe feeding magazine for off-line bellowing
- Conveyor for pipe removal
- Pipe magazine for socketed pipe collection
- Automatic Mecaring seal ring inserting equipment
- Automatic Mecaturn pipe packaging equipment

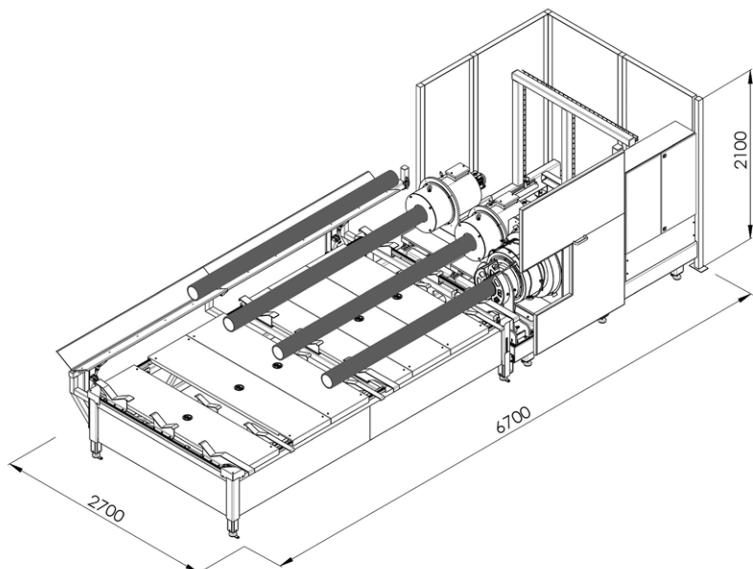

MECANOR

OY MECANOR-ENGINEERING AB

Heinolan Vanhatie 25

FI-15170 Lahti

Finland

TEL +358 40 195 6300

FAX +358 3 781 1082

E-MAIL mecanor@mecanor.com

WWW.mecanor.com